

CATOLOGO PARTI DI RICAMBIO TRINCIA SERIE TR8

CATALOGUE PIECES DE RECHANGE POUR BROYEUR SERIE TR8

TR8 SERIES SHREDDER SPARE PARTS CATALOGUE

ERSATZTEILEKATALOG HAECKSLER SERIE TR8

CATÁLOGO DE PIEZAS DE REPUESTO TRINCHADOR SERIA TR8

SICUREZZA E GARANZIA SOLO CON I RICAMBI ORIGINALI TORTELLA

SÉCURITÉ ET GARANTIE SEULEMENT AVEC DES PIÈCES D'ORIGINE TORTELLA

SAFETY AND DEPENDABILITY WITH GENUINE TORTELLA SPARE-PARTS ONLY

SICHERHEIT UND GARANTIE HABEN SIE NUR MIT ORIGINAL - TORTELLA - ERSATZTEILEN

SEGURIDAD Y GARANTIA SÓLO CON REPUESTOS ORIGINALES TORTELLA



INDUSTRIA MECCANICA F.LLI TORTELLA S.p.A
Via Civiltà del Lavoro, 77 66026 Ortona (CH) ITALY
tel. 085•9061788 • fax 085•9062404 • telex 600095 TORT I
Internet E-Mail: tortella@rgn.it

I**NORME PER LE ORDINAZIONI**

Le **Ordinazioni di parti di ricambio** devono essere corredate dalle seguenti indicazioni:

- Serie dell'attrezzo
- Modello
- Codice
- Anno di fabbricazione
- Numero di ordinazione della parte che si richiede (*come indicato nelle tavole e negli elenchi parti di ricambio*), in base al quale vengono evase le ordinazioni,

Inviare gli ordini a:

TORTELLA S.p.A.
VIA CIVILTÀ DEL LAVORO 77
66026 ORTONA (CHIETI) - Italy
E-MAIL: info@tortella.com
Tel.085/906981

F**COMMANDE DE PIÈCES DÉTACHÉES**

Les **commandes** doivent nous parvenir complètes des indications suivantes:

- Serie de l'outil
- Modele
- Code
- An de fabrication
- Numéro de commande de la pièce requise (*comme indiqué sur les planches et aux listes des pièces*), d'après lequel les commandes sont expédiées.

Envoyer la commande a:

TORTELLA S.p.A.
VIA CIVILTÀ DEL LAVORO 77
66026 ORTONA (CHIETI) - Italy
E-MAIL: info@tortella.com
Tel.085/906981

GB**ORDERING PARTS**

Orders for spare parts must include the following data:

- Tool series
- Model
- Code
- Year of fabrication
- Part number of the ordered spare, as given on plates and lists, that will be used to fill the order

Please send the order to:

TORTELLA S.p.A.
VIA CIVILTÀ DEL LAVORO 77
66026 ORTONA (CHIETI) - Italy
E-MAIL: info@tortella.com
Tel.085/906981

INDUSTRIA

MECCANICA

F.LLI

TORTELLA

S.p.A.

VANGATRICI — FRESATRICI

SERIE	<input type="text"/>	MOD.	<input type="text"/>
CODICE	<input type="text"/>	MATR.	<input type="text"/>
ANNO	<input type="text"/>	PESO KG.	<input type="text"/>

MADE IN ITALY

D**ANWEISUNGEN ZUR BESTELLUNG**

Bei **Bestellung** bitten wir stets folgendes anzugeben:

- Serie des geraets
- Modell
- Kode
- Fabrikationsjahr
- Bestellnummer des gewünschten Ersatzteils (*It. Bildtafeln u. Listen*), auf Grund derer die Lieferung erfolgt

Adressieren die bestellung zu:

TORTELLA S.p.A.
VIA CIVILTÀ DEL LAVORO 77
66026 ORTONA (CHIETI) - Italy
E-MAIL: info@tortella.com
Tel.085/906981

E**PEDIDOS DE REPUESTOS**

En todos los pedidos de piezas de repuesto tienen que consignarse los datos siguientes:

- Serie del equipo
- Modelo
- Año de fabricación
- Código
- Número de pedido de la pieza requerida (*el que coincidirá con el resenado en las listas de piezas de repuesto y las láminas*), en base al cual se evacua el pedido

Expedir los pedidos.

TORTELLA S.p.A.
VIA CIVILTÀ DEL LAVORO 77
66026 ORTONA (CHIETI) - Italy
E-MAIL: info@tortella.com
Tel.085/906981

I**RICERCA DELLE PARTI DI RICAMBIO**

Le parti di ricambio illustrate sono contraddistinte dal **n. di ordinazione** con a fianco tutte le indicazioni (*modifiche, ecc.*) sufficienti in generale per poter individuare le parti stesse direttamente sulle tavole.

Indicazioni e abbreviazioni usate nelle tavole:

- 2251958 = parte di normale fornitura
 2490890-4105000 = parti fornite in alternativa
1441000 = complessivo
 2251955 P.143 = complessivo le cui parti sono illustrate nella pag. 143
 1453090 P.143-144 = complessivo le cui parti sono indicate nelle pagine 143-144.

s = parte sinistra (*)
d = parte destra (*)

(*) Rispetto alla direzione di marcia dell'attrezzo.

F**RECHERCHE DES PIÈCES DÉTACHÉES**

Les pièces représentées sont repérées par le **n. de commande** accompagné de toutes les indications (*modifications, codes, etc.*), suffisant en général à repérer les pièces elles-mêmes directement sur les planches.

Symboles et abréviations utilisés sur les planches:

- 2251958 = pièce de fourniture standard
 2490890-4105000 = pièces livrées en alternative
1441000 = ensemble
 2251955 P.143 = ensemble dont les pièces figurent à la page 143
 1453090 P.143-144 = ensemble dont les pièces figurent à la pages 143-144.

s = pièce gauche (*)
d = pièce droite (*)

(*) Par rapport à la direction de marche de l'outil

GB**HOW TO LOCATE SPARES**

The spare parts illustrated are identified by respective **part numbers** together with other indications (*modifications, codes, etc.*), generally sufficient for direct location of parts on plate.

Indications and abbreviations used in the plates:

- 2251958 = standard supply part
 2490890-4105000 = parts supplied as an alternative
1441000 = assembly
 2251955 P.143 = assembly whose separate components are shown in page 143
 1453090 P.143-144 = assembly whose separate components are shown in page 143-144.

s = left (*)
d = right (*)

(*) With respect to running direction of the tool

**Sicurezza e garanzia solo
 con i ricambi originali TORTELLA**

**Sécurité et garantie seulement
 avec des pièces d'origine TORTELLA**

**Safety and dependability with
 genuine TORTELLA spare-parts only**

**Sicherheit und Garantie haben Sie nur
 mit Original - TORTELLA - Ersatzteilen**

**Seguridad y garantía sólo
 con repuestos originales TORTELLA**

D**AUFFINDEN DER ERSATZTEILE**

Die abgebildeten Ersatzteile sind mit den **Bestellnummern** und sämtlichen Angaben versehen (*Änderungen, Kennnummern usw.*), die im allgemeinen ausreichen, um die gewünschten Teile direkt auf den Bildtafeln zu ermitteln.

Erläuterungen und Abkürzungen auf den Bildtafeln:

- 2251958 = normalerweise gelieferter Teil
 2490890-4105000 = abwechselnd gelieferter Teil
1441000 = Zusammenbau
 2251955 P.143 = Zusammenbau, dessen Einzelteile in seite 143 abgebildet sind
 1453090 P.143-144 = Zusammenbau, dessen Einzelteile in seiten 143-144 abgebildet sind.

s = links (*)
d = rechts (*)

(*) Gegenüber der fahrriichtung des geräts

E**CÓMO SE BUSCAN LAS PIEZAS DE REPUESTO**

Cada pieza de recambio representada lleva el **número de pedido** acompañado de todas las indicaciones (*modificaciones, códigos, etc.*) que generalmente son suficientes para reconocer las mismas pieza en la lámina.

Notaciones y abreviaturas usadas en las láminas:

- 2251958 = pieza de suministro normal
 2490890-4105000 = piezas de suministro alternativo
1441000 = conjunto
 2251955 P.143 = conjunto cuyo despiece se ilustra en la pag. 143
 1453090 P.143-144 = conjunto cuyo despiece se ilustra en las pag. 143-144.

s = parte izquierda (*)
d = parte derecha (*)

(*) Respecto de la dirección de marcha del equipo

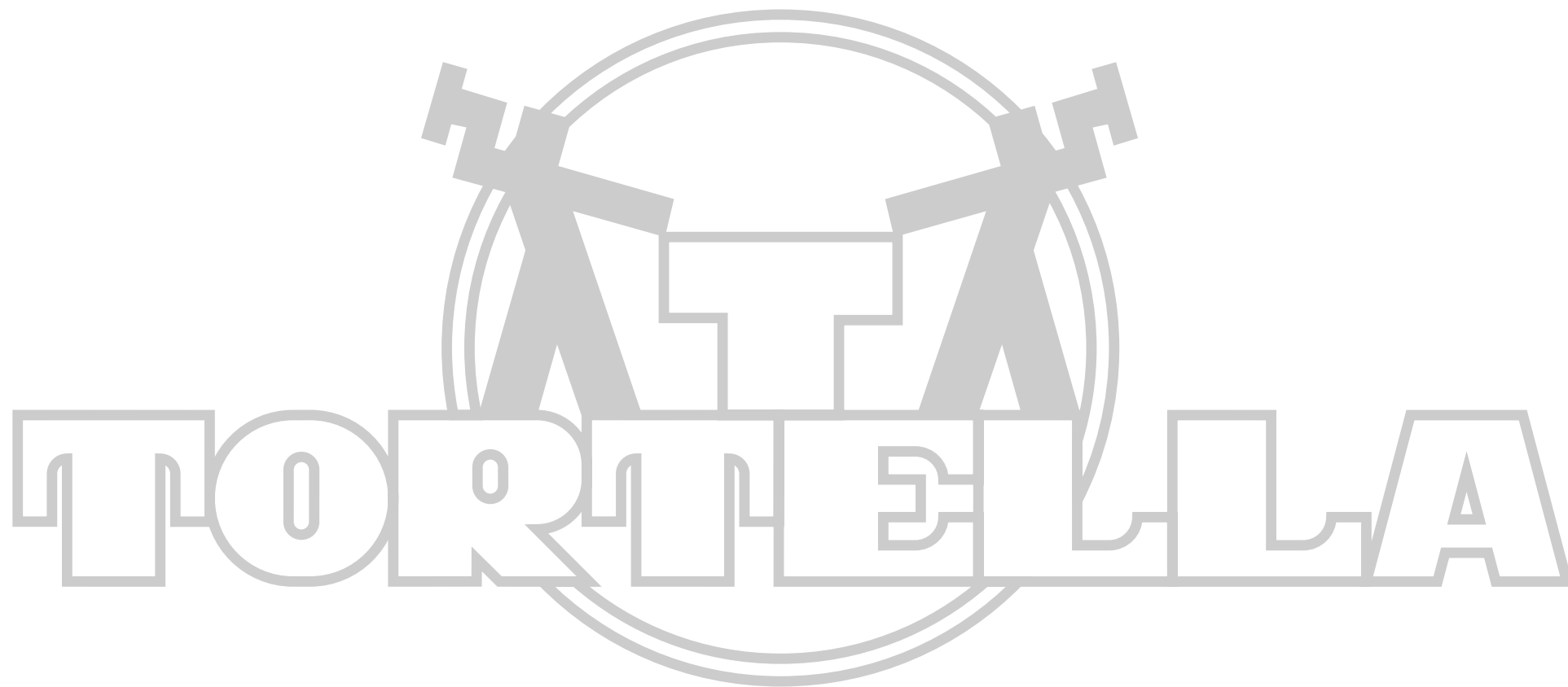

catalogo ricambi trincia

serie: TR8

potenze: hp 20-45

kw: 15-33

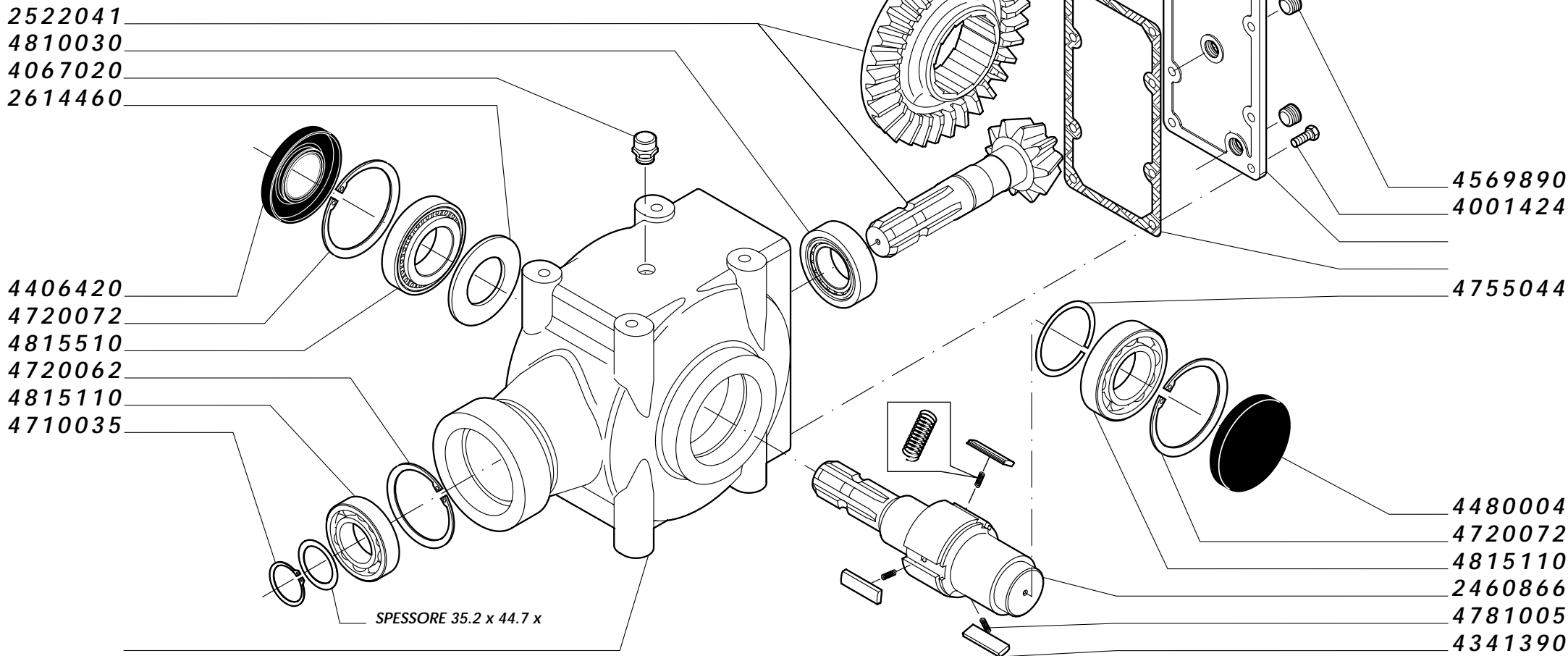

PAG. 562 1443900



fab Pubblicità - tel. 085/9062682

SERIE
TR8-TR9

COD.

MODELLI		
TR8 TUTTI		
TR9 Fino a 140		

SCATOLA 2041
C / RUOTA LIBERA 540 GIRI

PAGINA N°
562

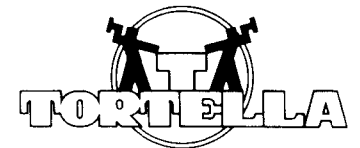
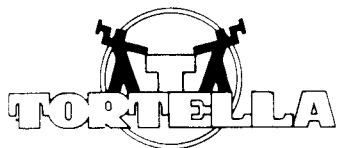
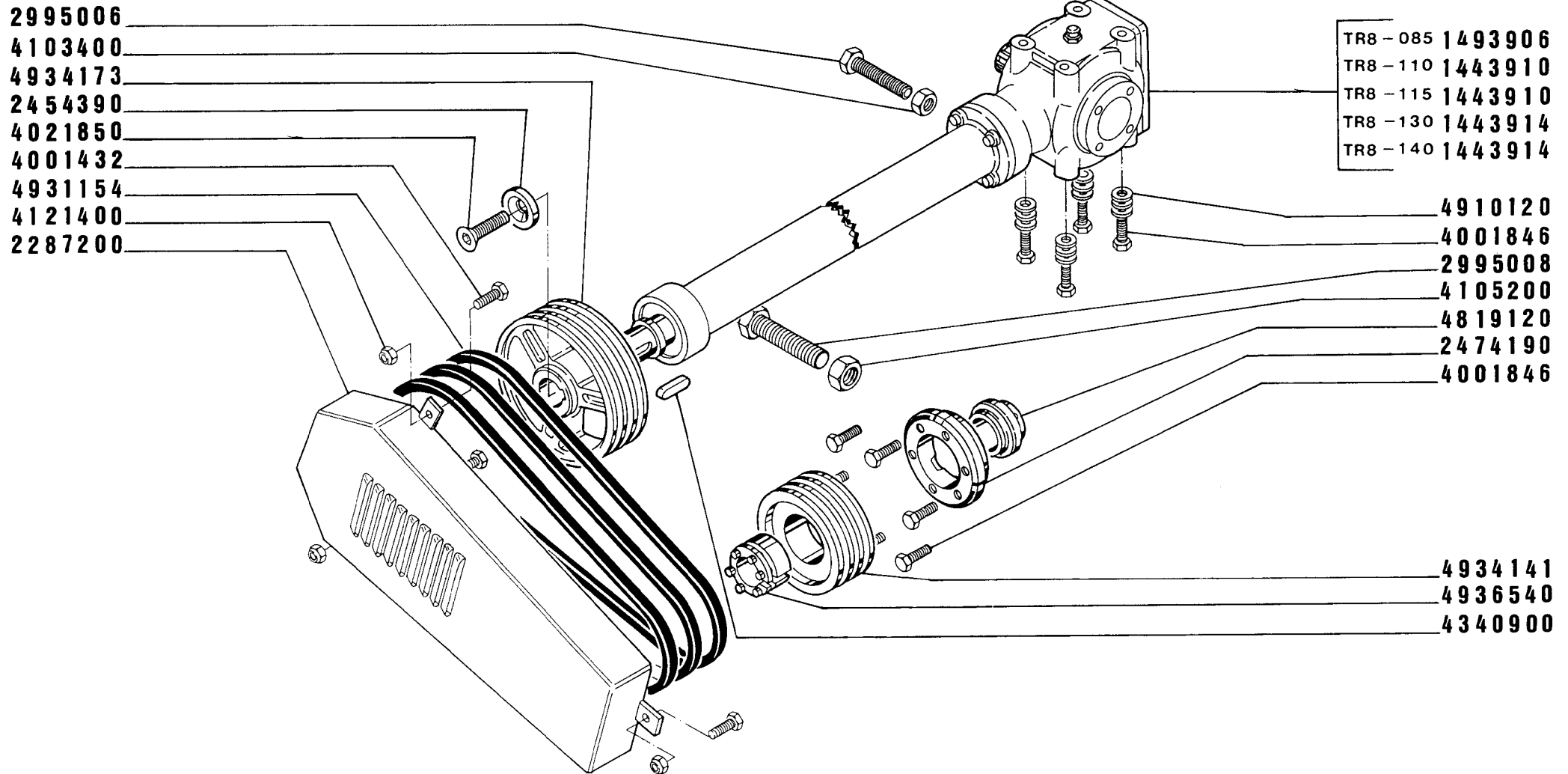

SERIE TR8	COD.	MODELLI TUTTI	GRUPPO TRASMISSIONE	PAGINA N° 459
---------------------	------	------------------	----------------------------	-------------------------

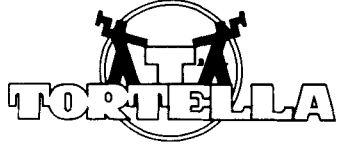
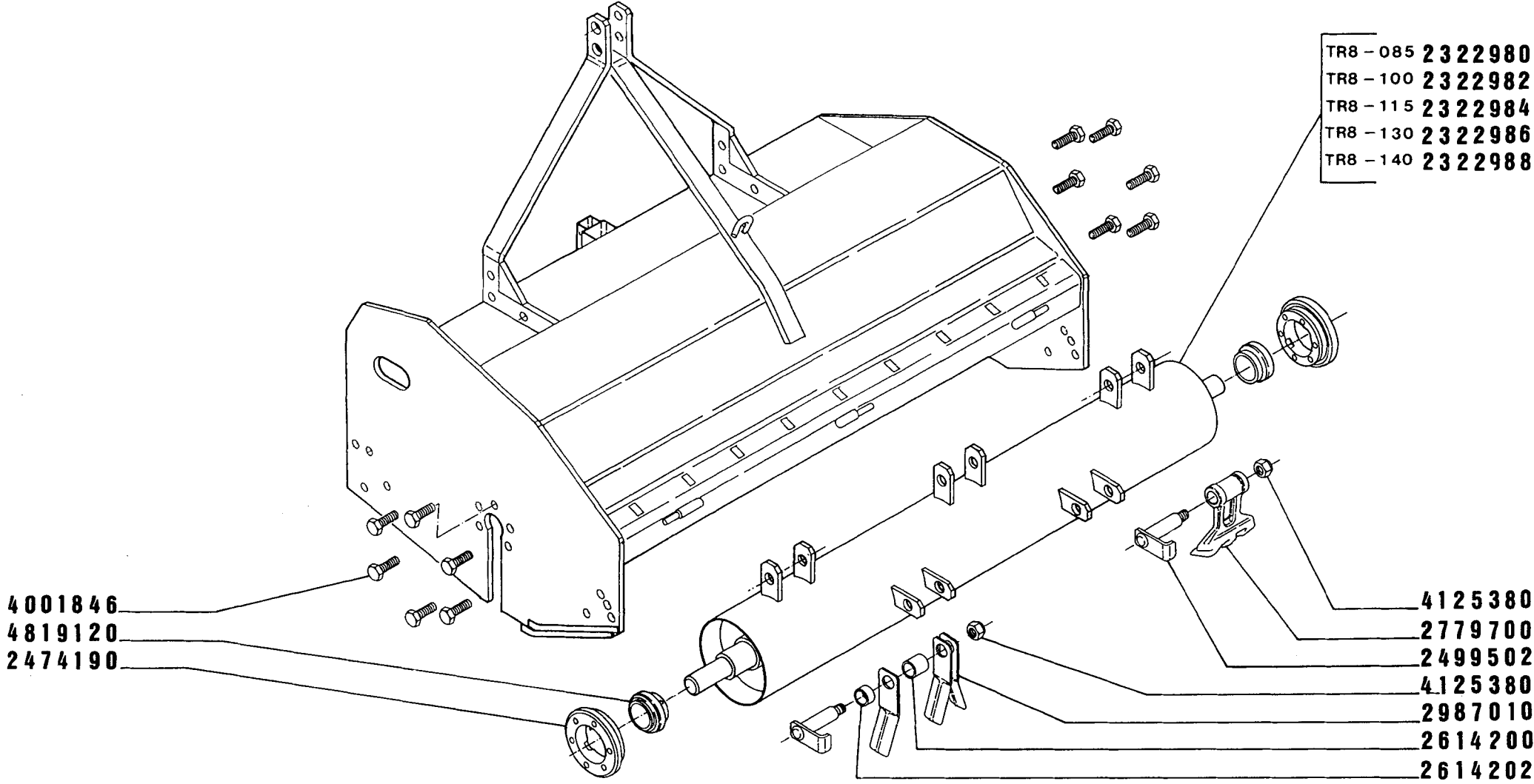

SERIE TR8	COD.	MODELLI TUTTI	ROTORE	PAGINA N° 467
---------------------	------	------------------	--------	-------------------------

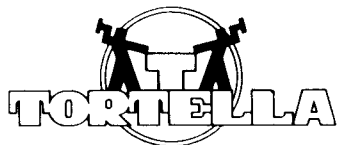
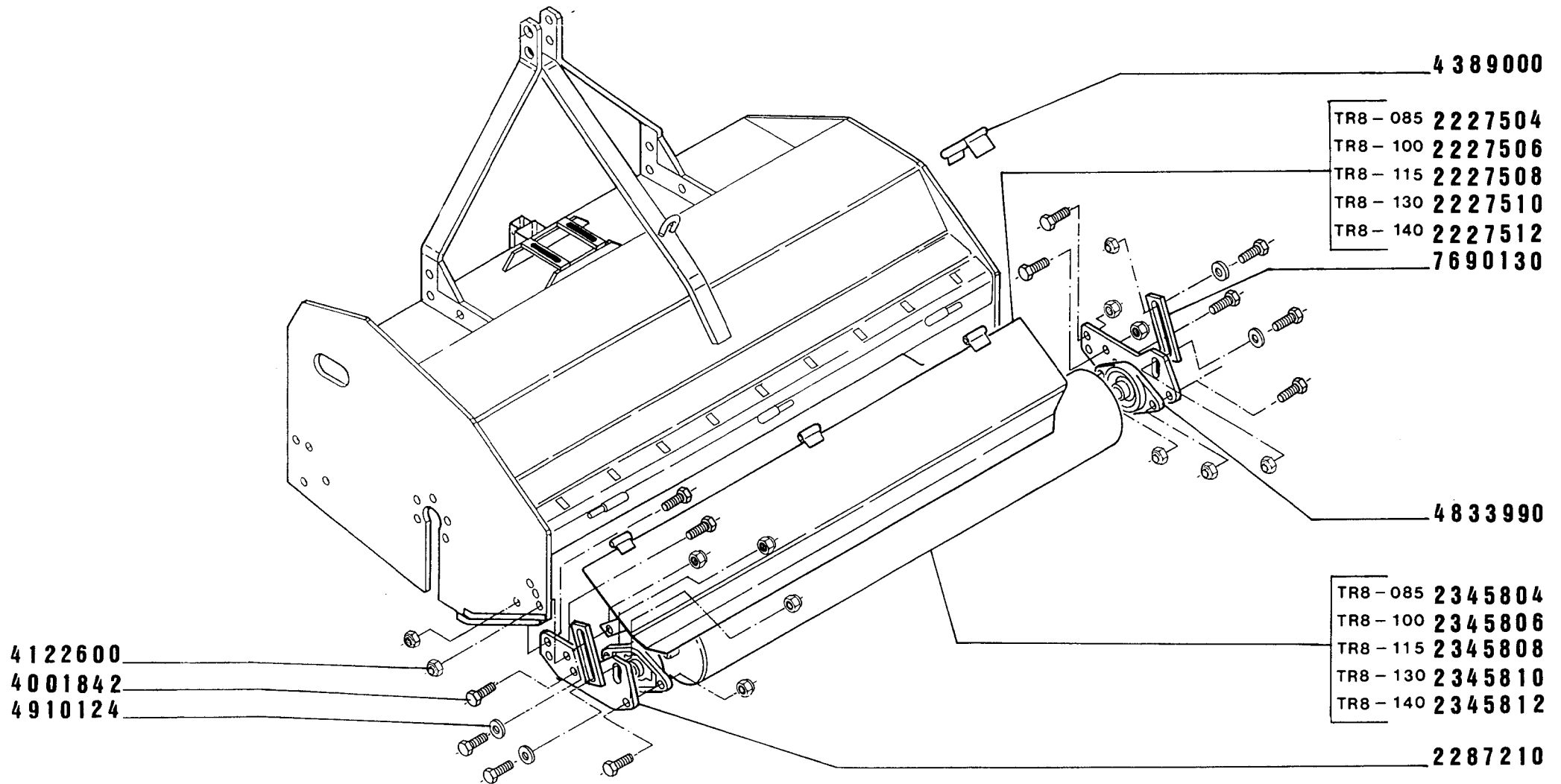

SERIE TR8	COD.	MODELLI TUTTI	SOSTEGNO RULLO E PORTA	PAGINA N° 457
---------------------	------	------------------	--	-------------------------

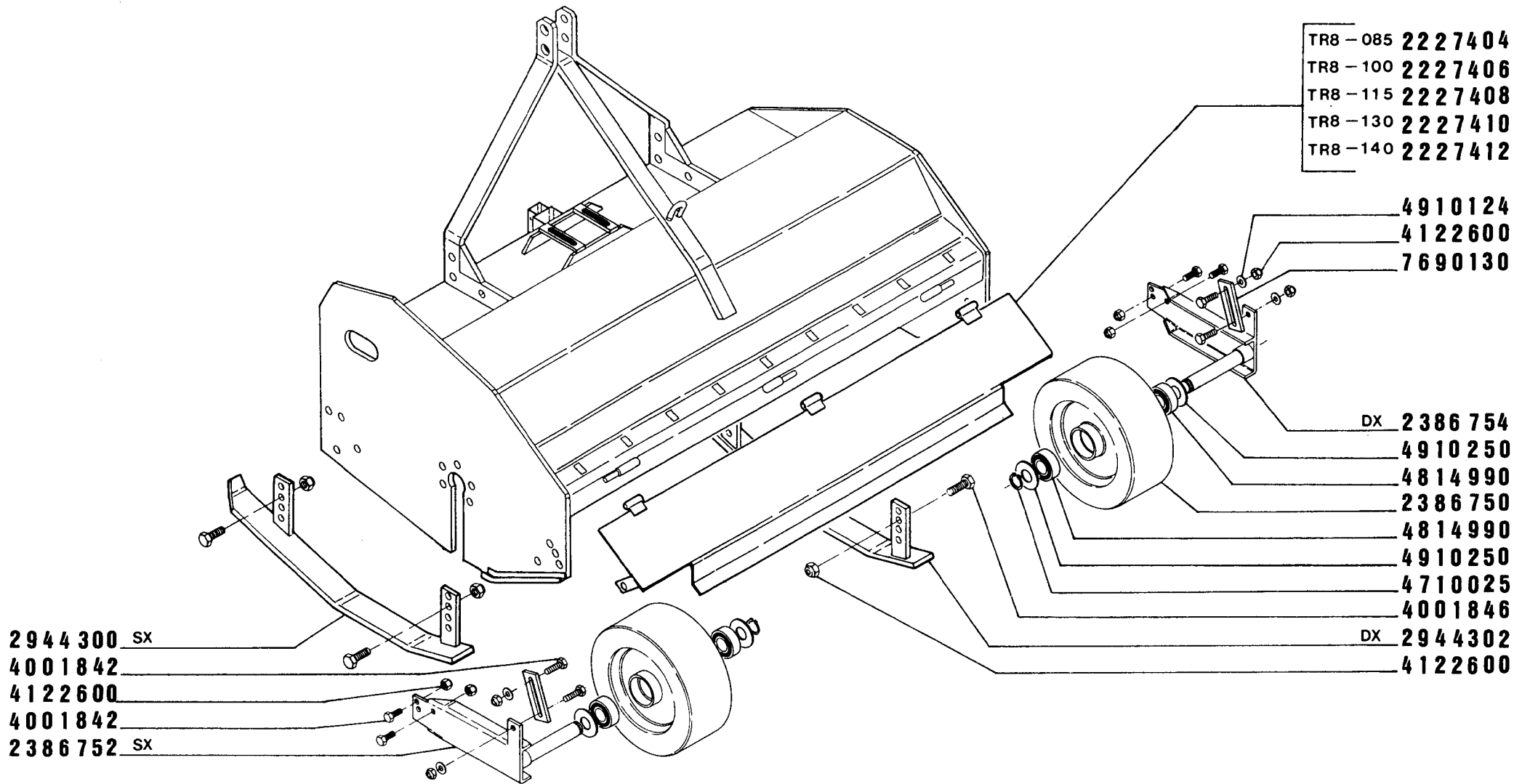

- TR8 - 085 2227404
- TR8 - 100 2227406
- TR8 - 115 2227408
- TR8 - 130 2227410
- TR8 - 140 2227412

- 4910124
- 4122600
- 7690130

- DX 2386754
- 4910250
- 4814990
- 2386750
- 4814990
- 4910250
- 4710025
- 4001846
- DX 2944302
- 4122600

- 2944300 SX
- 4001842
- 4122600
- 4001842
- 2386752 SX

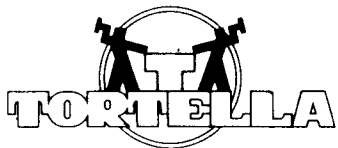

SERIE TR8	COD.	MODELLI TUTTI	RUOTE E SLITTE	PAGINA N° 469
---------------------	------	------------------	----------------	-------------------------

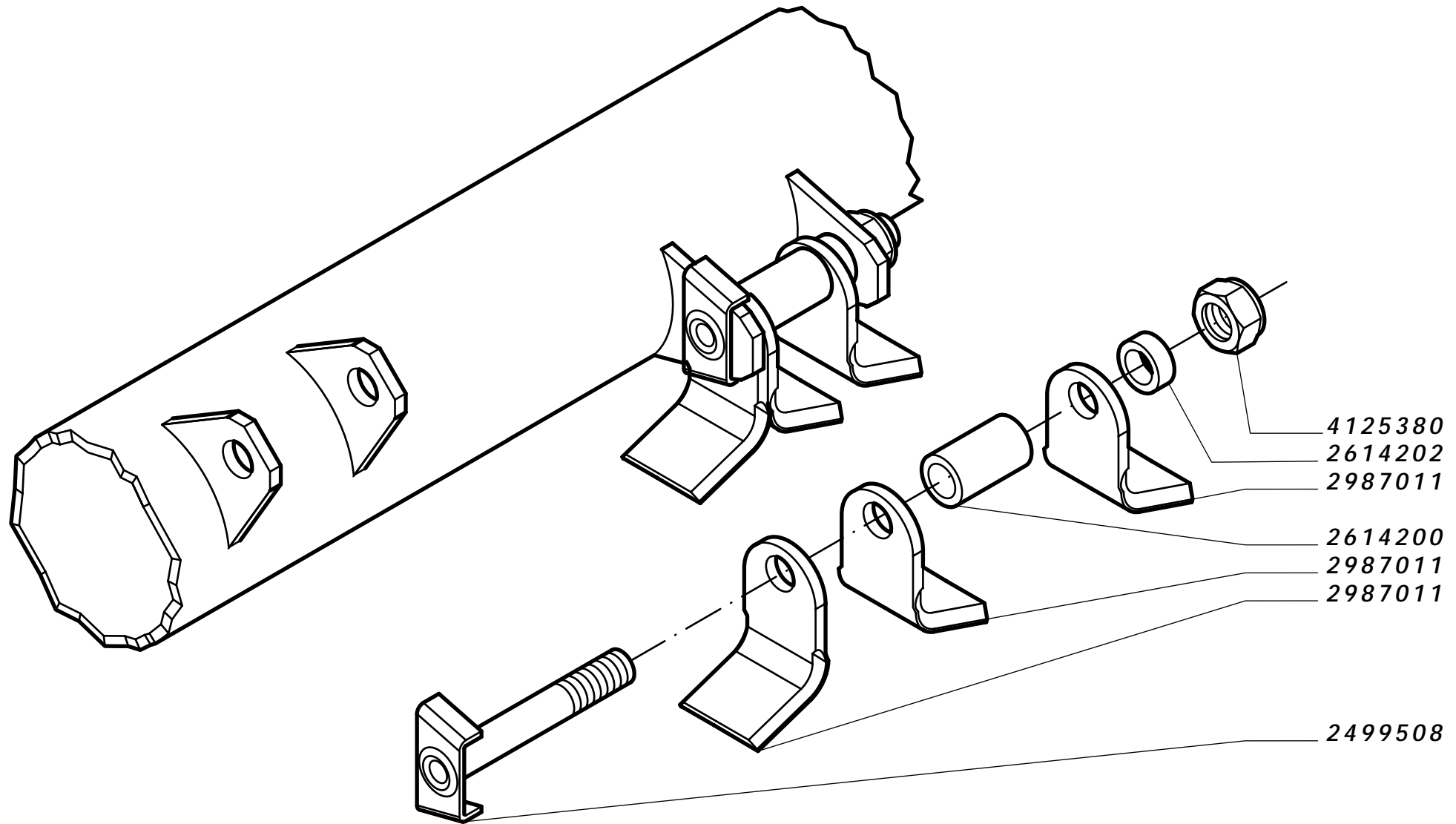

fab Pubblicità - tel. 085/9062682



SERIE
TR8-TR10

COD.

MODELLI
TUTTI

ASSIEME COLTELLI LUNGH

PAGINA

611

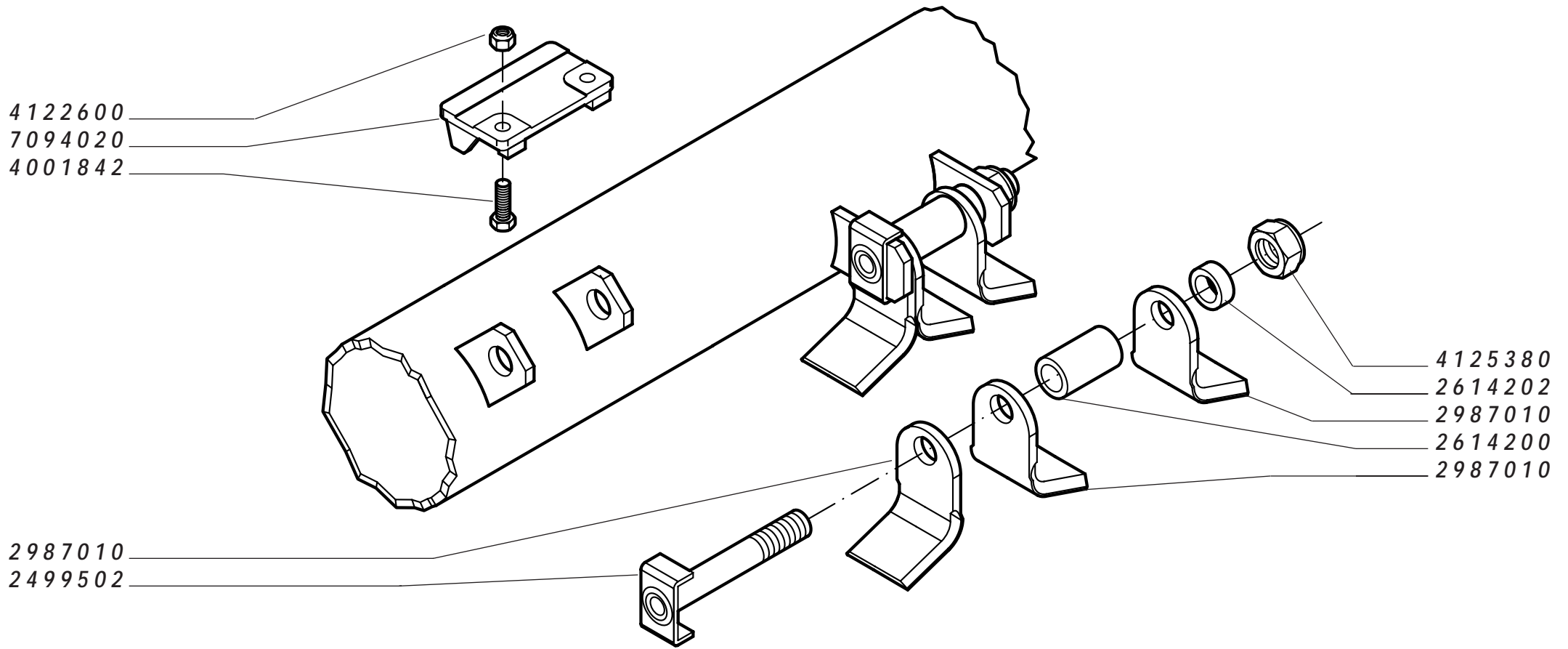

fab Pubblicità ORTONA-CH
Tel. - Fax 085-9062682

SERIE TR8 TR10	COD.	MODELLI TUTTI	ASSIEME COLTELLI		PAGINA N° 540
--------------------------	------	------------------	-------------------------	--	-------------------------

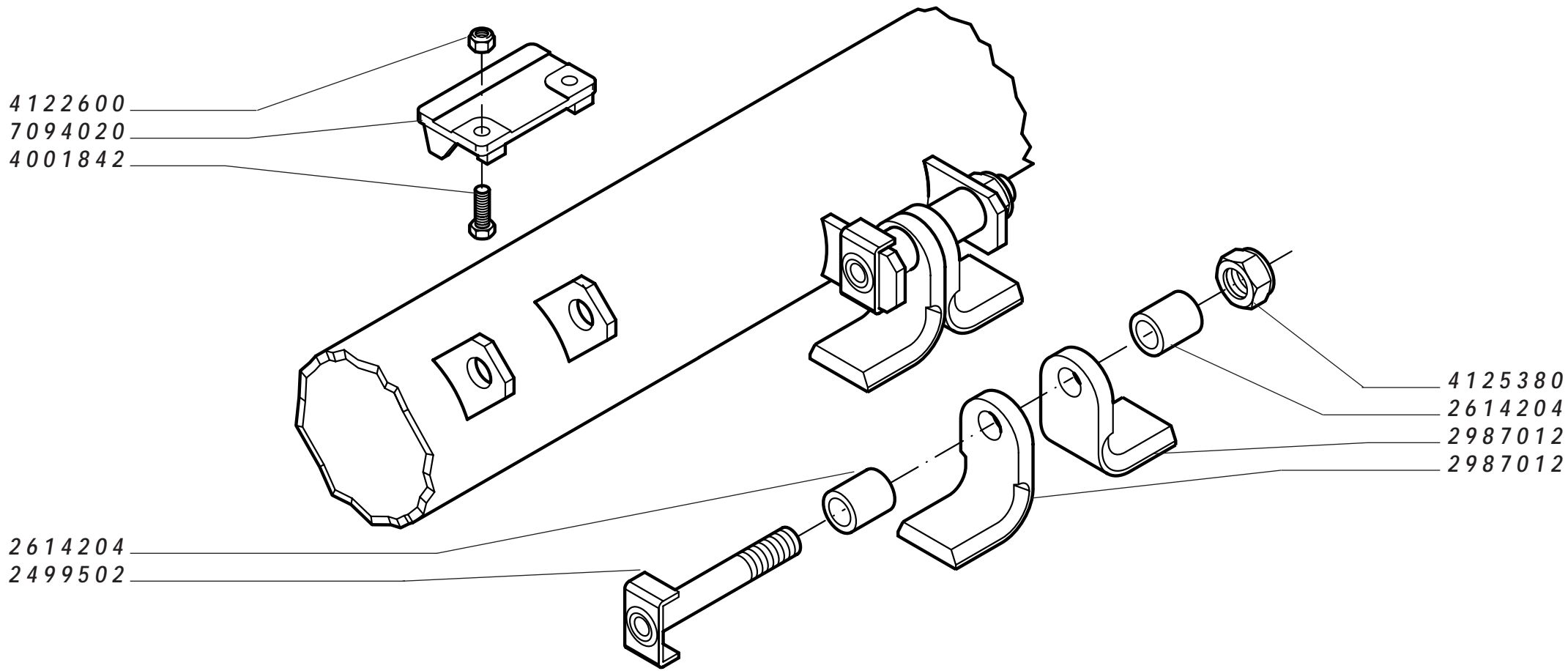

fab Pubblitè ORTONA-CH
tel. - fax 085-9062682

SERIE TR8 TR10	COD. 	MODELLI TUTTI	ASSIEME COLTELLI RINFORZATI		PAGINA N° 539
--------------------------	----------	------------------	--	--	-------------------------